

4

3

2

1

THIS DRAWING IS UNPUBLISHED. RELEASED FOR PUBLICATION 2011
 © COPYRIGHT 2011 TE CONNECTIVITY ALL RIGHTS RESERVED.

LOC	DIST	REVISIONS				
P	LTR	DESCRIPTION	DATE	DWN	APVD	
B	-	C	ECR-11-015005	19/07/11	JB	MG

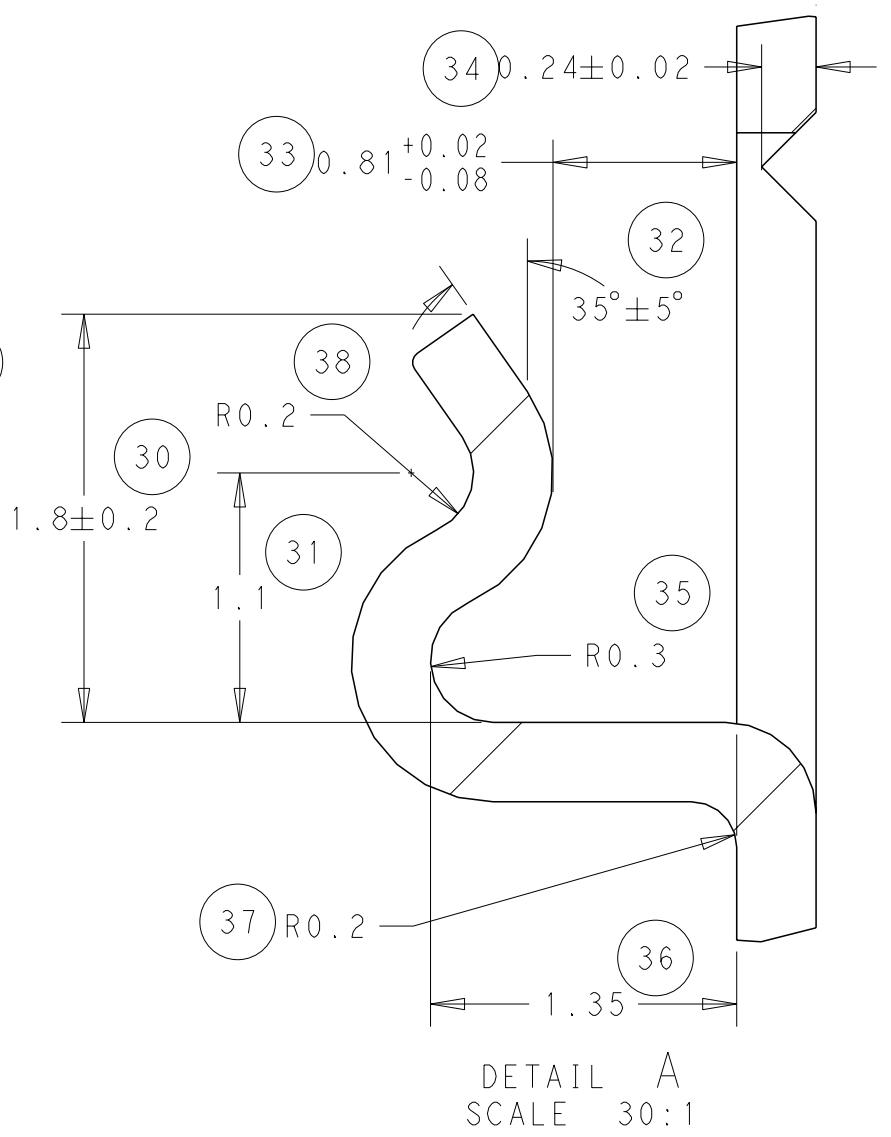
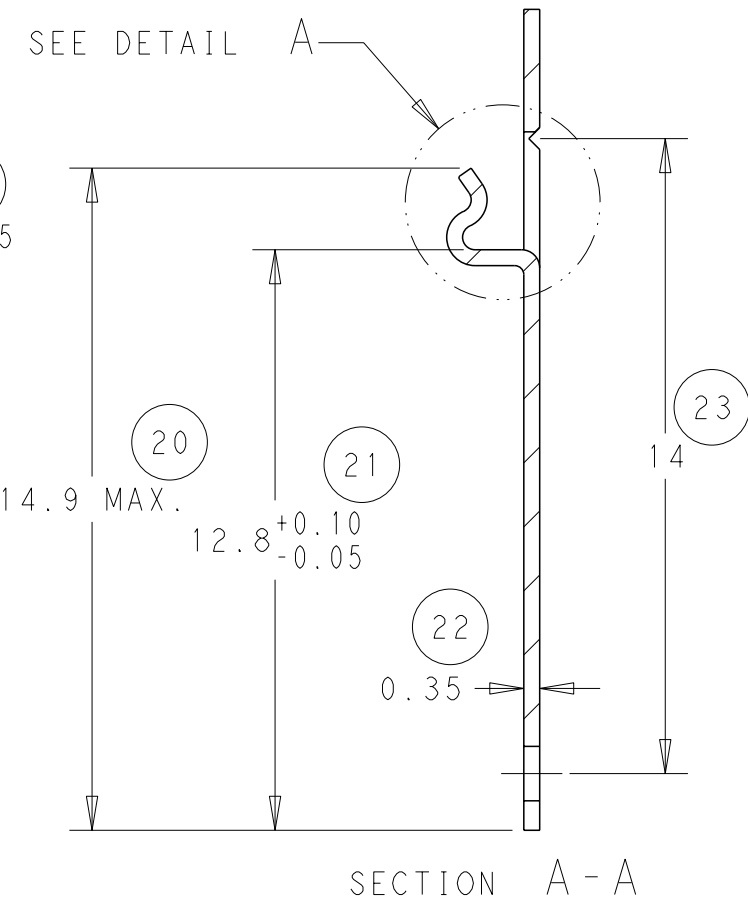
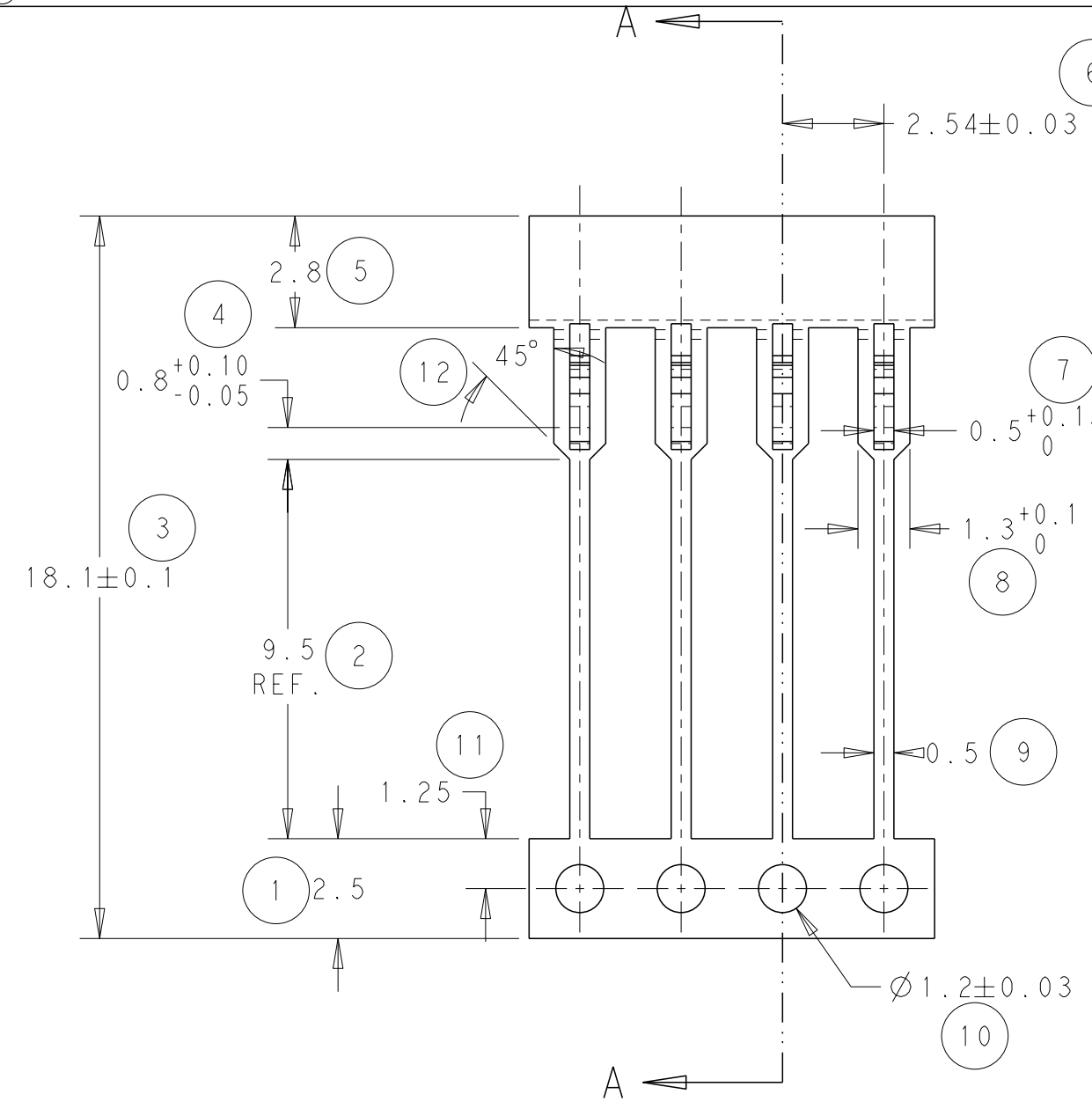

NOTE
 BOWING: AFTER UPPER TIE BAR REMOVAL - 1.5mm MAX. FOR 500mm
 PITCH: AFTER UPPER TIE BAR REMOVAL - 2.54 ± 0.127

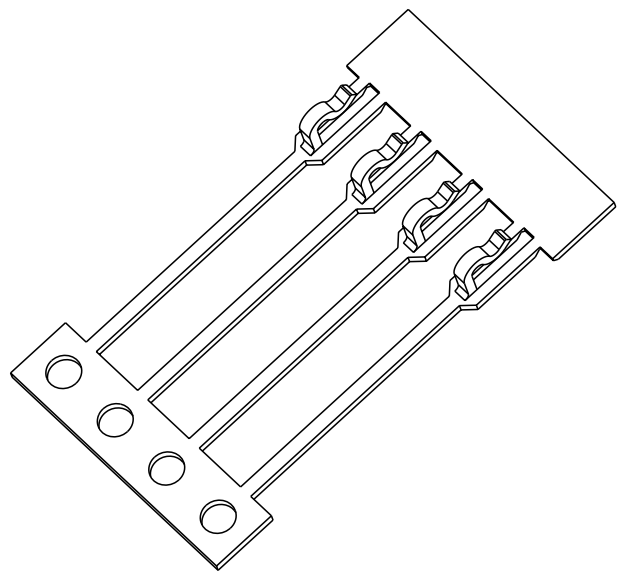

SCALE 4:1

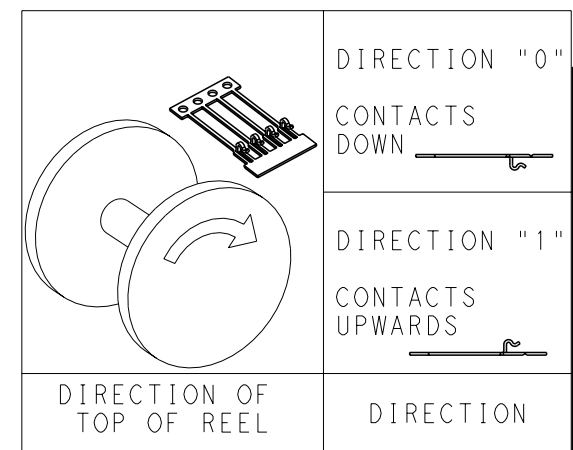

THIS DRAWING IS A CONTROLLED DOCUMENT.

DIMENSIONS:	TOLERANCES UNLESS OTHERWISE SPECIFIED:
mm	0 PLC ±-
	1 PLC ±-
	2 PLC ±0.05
	3 PLC ±-
	4 PLC ±-
	ANGLES ±0.5
MATERIAL	FINISH -
SEE ABOVE	

DWN	J. BRIGHT	19/07/11
CHK	M. GREENER	19/07/11
APVD	D. PENNINGTON	19/07/11
PRODUCT SPEC	-	
APPLICATION SPEC	-	
WEIGHT	-	

0	Ni & Sn	1544315-2
0	Sn	1544315-1
REELING	FINISH	PART NUMBER

STE TE Connectivity

NAME: SIL CONTACT

SIZE	CAGE CODE	DRAWING NO	RESTRICTED TO
A3	00779	C-1544315	-

CUSTOMER DRAWING SCALE NTS SHEET 1 OF 1 REV C