

PROD		LOC		DIST		REV		REVISIONS		DATE	APPD	
CODE	DF	FO	P	F	ZONE	LTR		DESCRIPTION				
5368								G	REV PER 0600-8454-99	JEB	01-00	DM

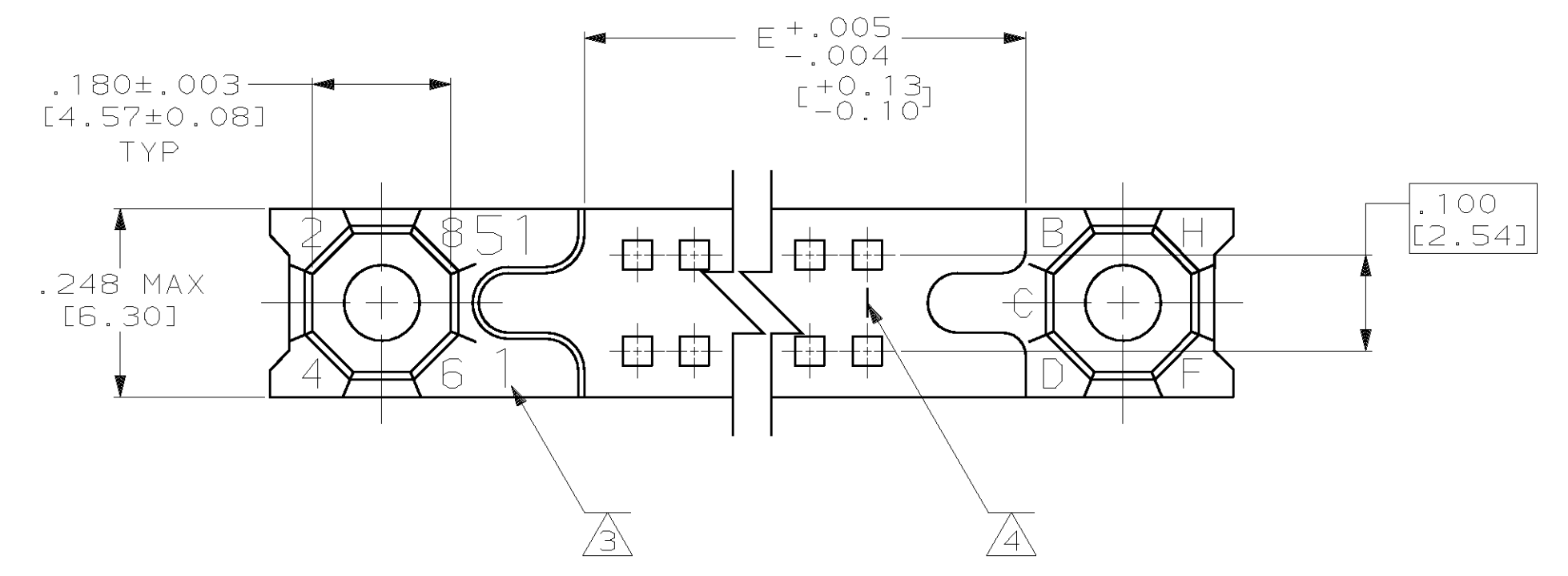
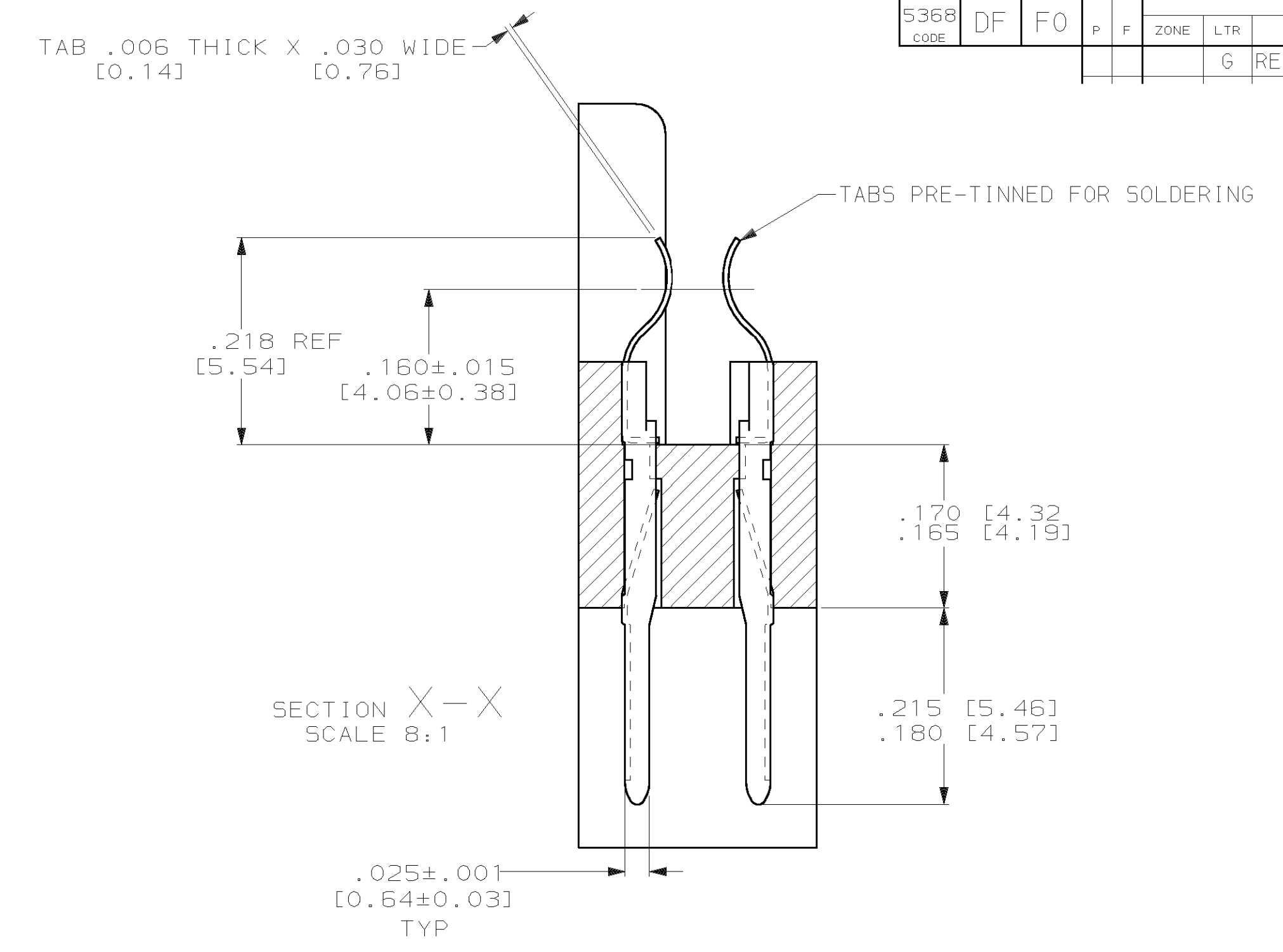
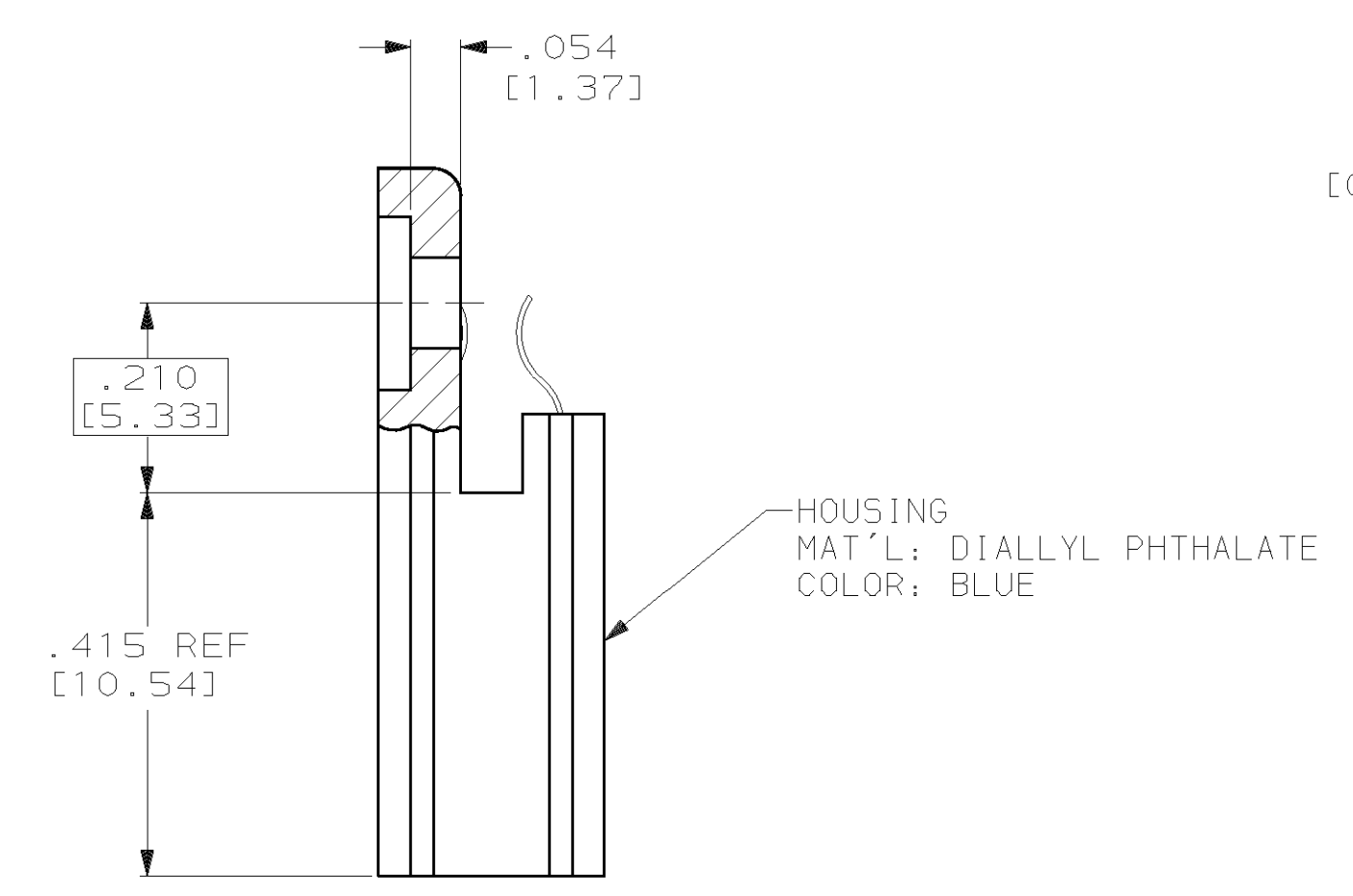
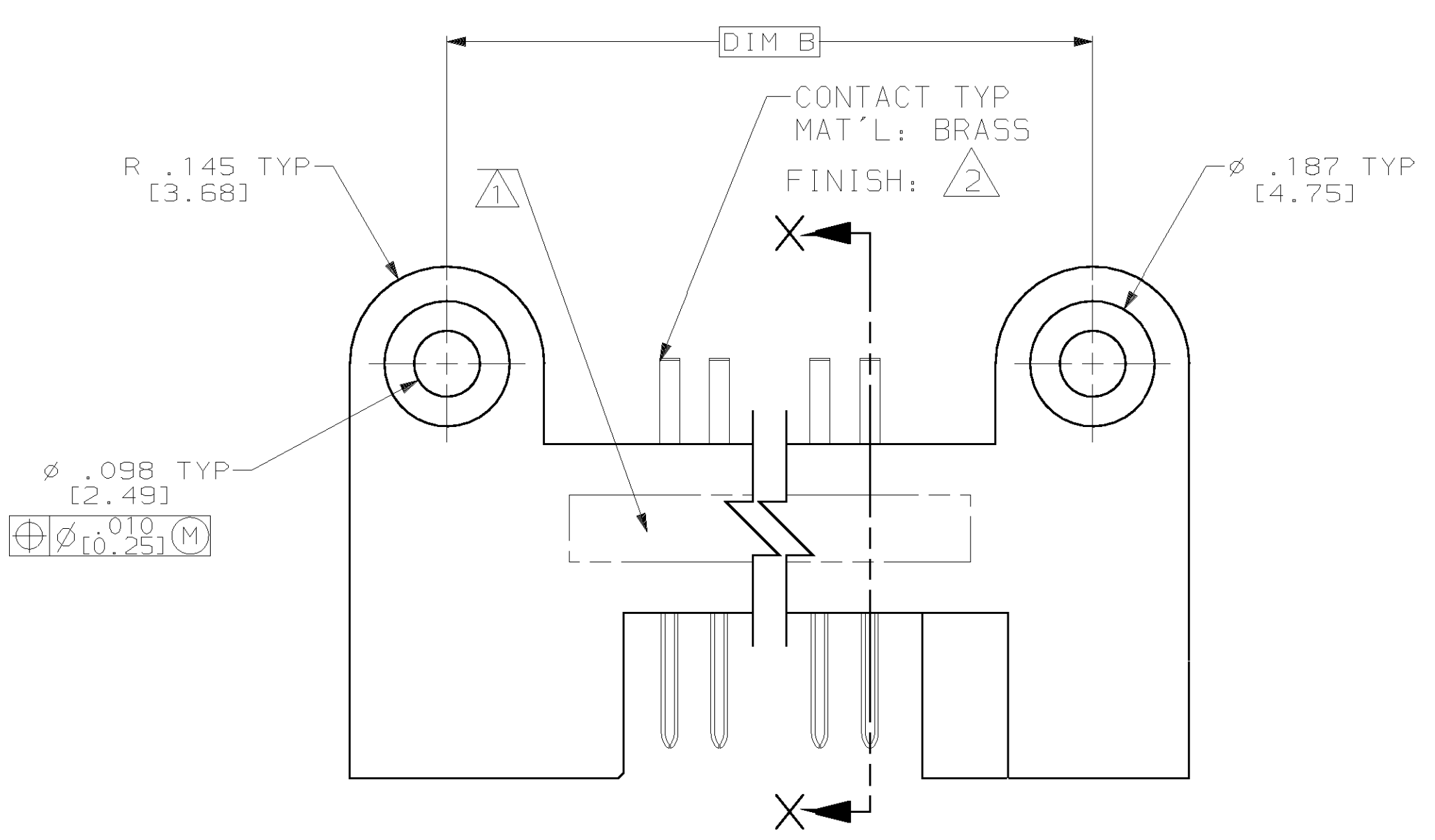
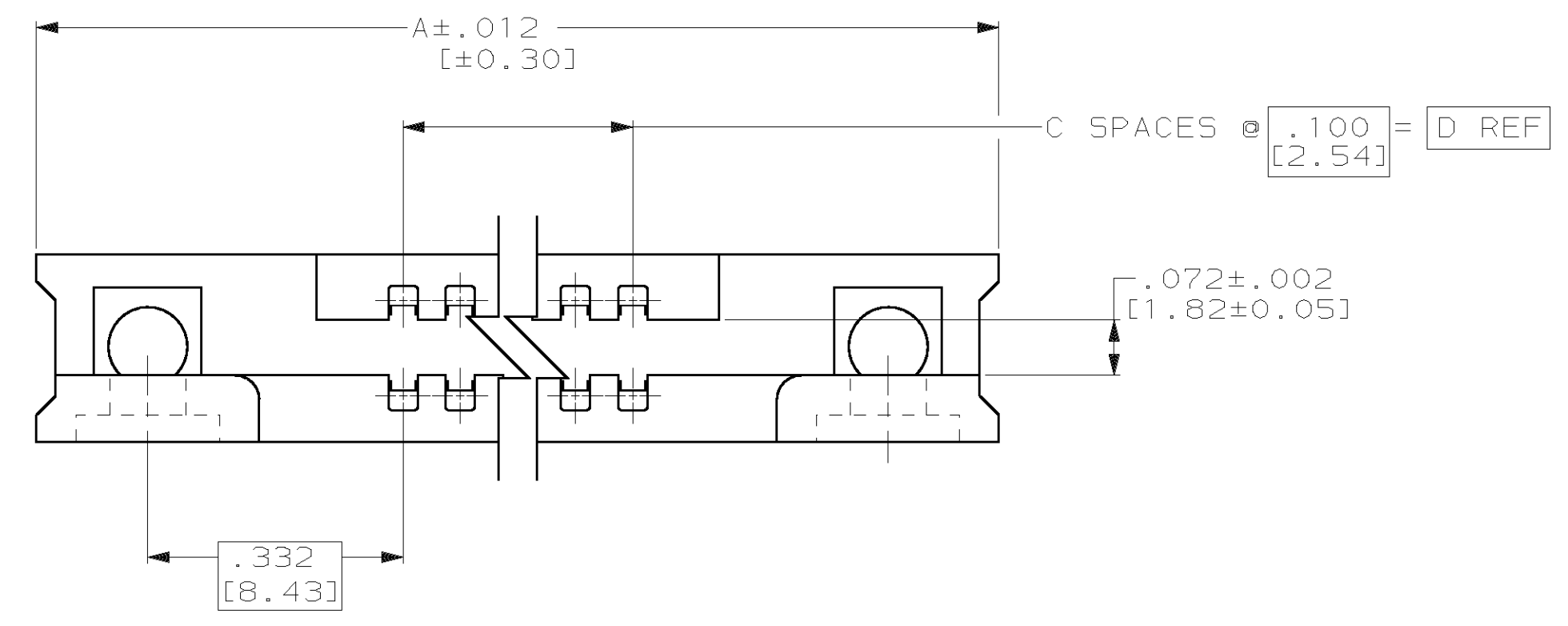

- 1 CUSTOMER PART NO., 13973, (AMP), DATE CODE AND (AMP PART NO.) MARKED IN THIS AREA.
- 2 FINISH: .000030 [0.00076] GOLD IN CONTACT AREA, .000100 [0.00254] TIN-LEAD ON TAILS, OVER .000050 [0.00127] NICKEL, OVER ENTIRE CONTACT.
- 3 CAVITY IDENT NUMBERS MARKED OR MOLDED IN THIS AREA. (SEE TABLE)
- 4 LINES INDICATING EVERY FIFTH CAVITY MARKED OR MOLDED ON MATING FACE.
- 5 ACCEPTANCE INSPECTION PER PARA 4.3 OF LITTON DWG. 861700.

OBSOLETE	-	2606366-1	51 - 1	5.175 [131.45]	4.900 [124.46]	49	5.565 [141.35]	5.855 [148.72]	100	583804-4
OBSOLETE	-	2285961-1	51 - 1	5.175 [131.45]	4.900 [124.46]	49	5.565 [141.35]	5.855 [148.72]	100	583804-3
	1 3	861700-3	56 - 1	5.675 [144.15]	5.400 [137.16]	54	6.065 [154.05]	6.355 [161.42]	110	583804-2
	1 3	861700-1	16 - 1	1.675 [42.55]	1.400 [35.56]	14	2.065 [52.45]	2.355 [59.82]	30	583804-1
REMARKS	CUSTOMER PART NO.	CAVITY IDENTIFICATION	E	D	C	B	A	NO OF POSN	PART NUMBER	

DO NOT SCALE PRINT. UNLESS SPECIFIED DIMENSIONS IN INCHES [mm] TOLERANCES ON:

1	DR 5-28-97 C.C. THOMAS	AMP Incorporated Harrisburg, PA 17105-3508
2	CHK 6-17-97 D. MILLER	
3	APPD 6-17-97 D. MILLER	NAME
4	APPD 6-17-97 C.C. THOMAS	PIN HEADER ASSEMBLY, 1000 SERIES BOX
MATERIAL	PRODUCT SPEC	
FINISH	APPLICATION SPEC	SIZE D
		CAGE CODE 00779
		DRAWING NO. 583804
		SCALE 5:1
		SHEET 1 OF 1