

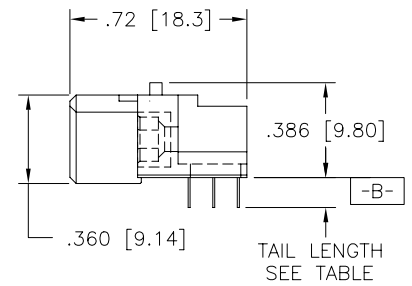

FCIconnect.com

Copyright FCI

PRODUCT NUMBER
SEE TABLE

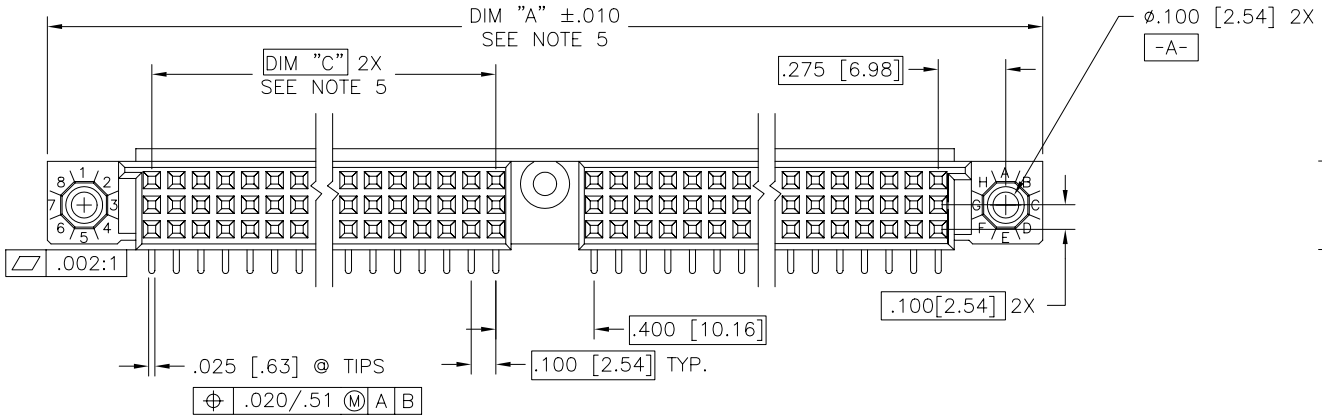
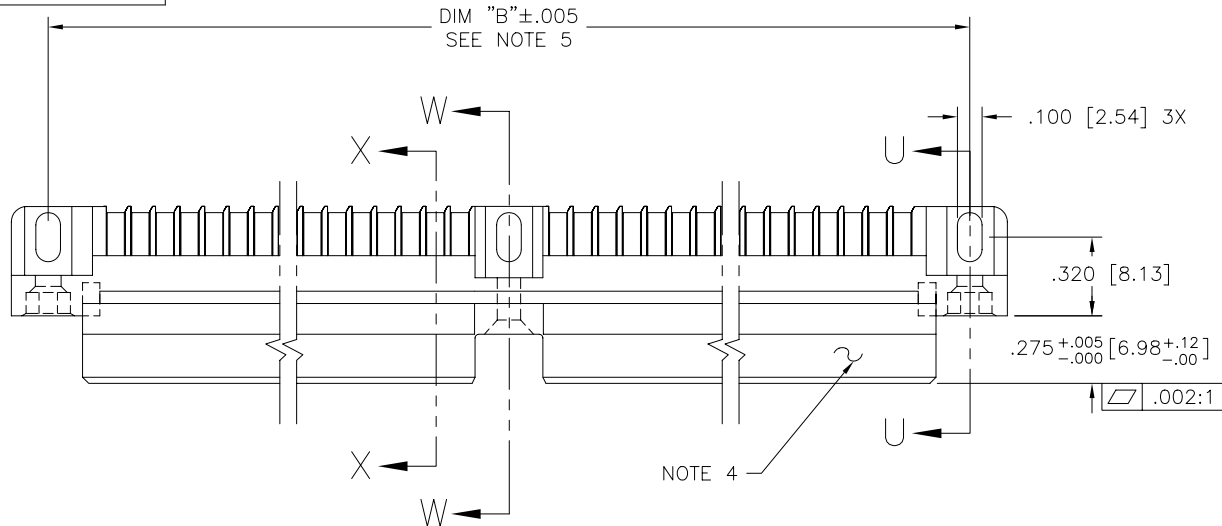

mat'l. code SEE NOTE 3		surface ISO 1302 ✓		tolerance ISO 406 ISO 1101		projection INCH/MM		product family HPC	
ltr		ecn no		date		tolerances unless otherwise specified		title	
G	v40954	GIP	5/31/94	angles	linear	.xx ±.01/.3	INCH/MM	3 ROW R/A RECEPTACLE SOLDER TAIL, 1 GUIDE PIN	
H	v41511	GAH	10/13/94			.xxx ±.005/.13			
J	v82250	HTB	12/28/98	σ±2'		.xxxx ±.0020/.051	scale 1:1		
K	v00253	JWS	1/12/00	dr	D. HORCHLER	10/18/05		dwg no	
L	v03-0301	TAB	4/30/03	engr	T. BREWBAKER	10/18/05		50001	
M	v05-0639	DCH	10/18/05	chr	T. BREWBAKER	10/18/05		A3	
N	M06-0255	AEA	7/06/06	app	T. BREWBAKER	10/18/05		type Product Customer Drawing	
sheet	revision	N	N	N					
index	sheet	1	2	3					

form: A3

PRODUCT NUMBER
SEE TABLE

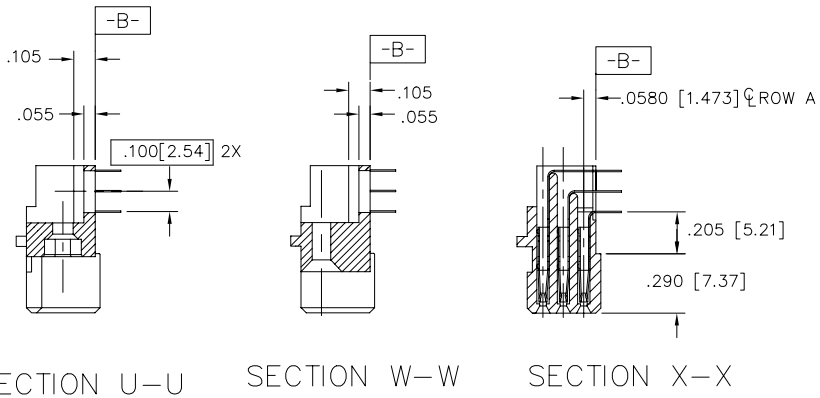

NOTES:

1. PRODUCT NUMBERING CODE:
50001 - X YYY Z LF
LEAD FREE (OPTIONAL)
TAIL LENGTH SEE TABLE
NO. OF POSITIONS SEE NOTE 2
PLATING SEE TABLE
BASE NUMBER

- PRODUCT NUMBERING CODE FOR
SELECT LOAD PART NUMBERS:
50001 - XXXXX LF
LEAD FREE (OPTIONAL)
SEQUENCE NUMBER
ALWAYS 'XX'
BASE NUMBER

- ② THIS PRODUCT IS CONFIGURED IN SIZES OF 20 THRU 122 COLUMNS IN INCREMENTS OF TWO.
i.e.: 20,22,24,26.....118,120,122.
- ③ HOUSING MATERIAL: GLASS AND MINERAL FILLED THERMOPLASTIC.
CONTACT MATERIAL: BeCu
- ④ COMPANY NAME, PART NUMBER AND LOT CODE TO APPEAR ON THIS SURFACE PER BUS-12-108.
- ⑤ LENGTH FORMUALS:
DIM A = .100/2.54 X NO. OF COLUMNS + 1.05/26.7
DIM B = .100/2.54 X NO. OF COLUMNS + .750/19.05
DIM C = .100/2.54 X NO. OF COLUMNS DIVIDED BY 2 - .100/2.54
6. PRODUCT WITH "LF" SUFFIX MEETS EUROPEAN UNION DIRECTIVES AND OTHER COUNTRY REGULATIONS AS DESCRIBED IN GS-22-008.
7. THIS HOUSING (WITH "LF" SUFFIX) WILL WITHSTAND EXPOSURE TO 260°C PEAK TEMPERATURES FOR 10-30 SECONDS IN A CONVECTION, INFRA-RED OR VAPOR PHASE REFLOW OVEN.

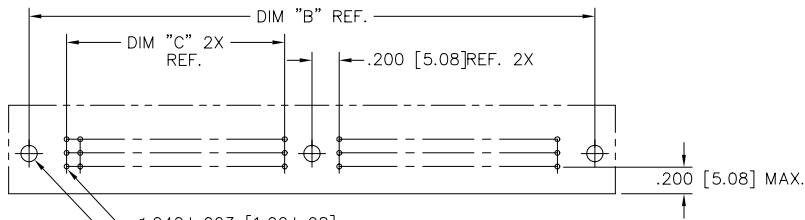

RECOMMENDED PCB LAYOUT
(ALL HOLES LOCATED ON .100 [2.54] GRID UNLESS OTHERWISE SPECIFIED)

mat'l. code SEE NOTE 3		surface ISO 1302 ✓	tolerance ISO 406 ISO 1101	projection ⊕	product family HPC
ltr	ecn	no	dr	date	tolerances unless otherwise specified
N					angles linear .xx ±.01/.3 .xxx ±.005/.13 σ±2' .xxxx ±.0020/.051
dr D. HORCHLER 10/18/05					INCH/MM
enr T. BREWBAKER 10/18/05					scale 1:1
chr T. BREWBAKER 10/18/05					dwg no
app T. BREWBAKER 10/18/05					sheet 2 of 3 size
					50001 A3
					type Product Customer Drawing
sheet index	revision sheet				

PRODUCT NUMBER	CONTACT PLATING	TAIL PLATING	TAIL LENGTH
50001-1YYYYE	30u" /0.76u Au	TIN/LEAD	.125±.010 / 3.18±.25
50001-1YYYYF	30u" /0.76u Au	TIN/LEAD	.145±.010 / 3.68±.25
50001-1YYYYH	30u" /0.76u Au	TIN/LEAD	.180±.010 / 4.57±.25
50001-3YYYYE	50u" /1.27u Au	TIN/LEAD	.125±.010 / 3.18±.25
50001-3YYYYF	50u" /1.27u Au	TIN/LEAD	.145±.010 / 3.68±.25
50001-3YYYYH	50u" /1.27u Au	TIN/LEAD	.180±.010 / 4.57±.25
50001-5YYYYE	30u" /0.76u GXT	TIN/LEAD	.125±.010 / 3.18±.25
50001-5YYYYELF	30u" /0.76u GXT	TIN	.125±.010 / 3.18±.25
50001-5YYYYF	30u" /0.76u GXT	TIN/LEAD	.145±.010 / 3.68±.25
50001-5YYYYFLF	30u" /0.76u GXT	TIN	.145±.010 / 3.68±.25
50001-5YYYYH	30u" /0.76u GXT	TIN/LEAD	.180±.010 / 4.57±.25
50001-5YYYYHLF	30u" /0.76u GXT	TIN	.180±.010 / 4.57±.25



Copyright FCI

mat'l. code SEE NOTE 3		surface ISO 1302 ✓	tolerance ISO 406 ISO 1101	projection 	product family HPC
ltr	ecn no	dr	date	tolerances unless otherwise specified	title 3 ROW R/A RECEPTACLE SOLDER TAIL, 1 GUIDE PIN
N				angles linear °.xx ±.01/.3 .xxx ±.005/.13 .xxxx ±.0020/.051	
		dr	D. HORCHLER	10/18/05	dwg no 50001 sheet 3 of 3 size A3
		enr	T. BREWBAKER	10/18/05	
		chr	T. BREWBAKER	10/18/05	
		app	T. BREWBAKER	10/18/05	
sheet index	revision sheet				type Product Customer Drawing

form: A3